



Owner's Manual

Model#: SGX110, SGX150, SGX200, & SGX300
Skid Sprayers 110, 150, 200, & 300 Gallons

Dealer: _____
Contact: _____
Phone: _____
Model #: _____
Serial #: _____

Manufactured by PBZ LLC
A Paul B Zimmerman Inc. Company
www.CropCareEquipment.com

Form: SGXOM
Rev. B Date: 10/25

Table Of Contents

Identification of Machine	3
Specifications.....	3
Introduction	3
Safety	4-8
Safety Alert Symbol	4
Signal Words.....	4
Hazards.....	5-6
Preparation for Use	5-6
General Guidelines.....	5
Chemical Warnings	5
Pump Precautions	6
Spraying Preparation.....	6
During Use	7-8
Clearing Blockages and Cleaning	7
Transporting the Sprayer	7
Maintenance and Adjustment	8
After Use / Storage	8
Safety Signs	8
Operation	9-16
Controls.....	9
Operating Instructions	10-12
Pre-start Instructions.....	10-12
Preparing the Sprayer	10
Calibrating The Sprayer	11
Adjusting the Spray Pressure.....	12
Preparing To Spray	12
Starting Instructions.....	13
Shut-Down Instructions	13
Instructions for Clearing Blockages and Cleaning.....	14
Troubleshooting	15
Maintenance and Adjustments	16-18
Maintenance Schedules.....	16
Maintenance Procedures.....	17
Every Use	17
Every Season	17
Preparing the Sprayer for Winterizing.....	17
Winterizing the Sprayer.....	18
Maintenance Materials.....	18
Storage	18
Accessories and Attachments.....	19
Gas Engine Electric Start Option.....	19
Electric Hose Reel Option	20
Warranty Information	21
Warranty Coverage	21
Warranty is Void if.....	21
Getting Warranty Service.....	21
Ordering Parts.....	21

Identification of Machine

- Model #'s: SGX110, SGX150, SGX200, and SGX300
- The serial plate is located on the tank saddle.

General Specifications

Tank capacity 110, 150, 200, and 300 gallons

Weights (Base Unit only, does not include optional spray booms, see boom owner's manual for boom weight):

(Tank Empty):

- 110 Gallon 361 lbs
- 150 Gallon 376 lbs
- 200 Gallon 430 lbs
- 300 Gallon 450 lbs

(Tank Full *):

- 110 Gallon 1,279 lbs
- 150 Gallon 1,627 lbs
- 200 Gallon 2,098 lbs
- 300 Gallon 2,952 lbs

* Weights calculated based on weight of water (8.34 lbs/Gal), and will vary based on other fluids

Overall Dimensions (Base Unit only, does not include optional spray booms, see boom owner's manual for boom specs):

- 110 Gallon 79" L x 32" W x 51" H
- 150 Gallon 79" L x 32" W x 51" H
- 200 Gallon 94" L x 38" W x 51" H
- 300 Gallon 94" L x 38" W x 51" H

Introduction

Please read and understand this manual and its instructions and warnings completely before operating the sprayer.

- Familiarize yourself and other operators with the sprayer's components and how all parts are operated.
- Read and understand the chemical manufacturer's labels, warnings, and instructions.
- Know and fulfill all state pesticide applicator license requirements.
- Contact your authorized CropCare® Dealer for help interpreting the owners manual.
- Read and follow ALL of the chemical manufacturer's labels, warnings, and instructions about chemical usage! A material safety data sheet (MSDS) should be provided by the chemical manufacturer. CropCare® is not liable for misuse or mishandling of chemicals before spraying, during spraying, and after spraying.

Safety Alert Symbol

-The safety alert symbol for safety signs & decals that contain one of the three signal words (DANGER, WARNING, & CAUTION) will appear as shown in figure 1.



Figure 1: Safety Alert Symbol

Signal Words

-There are three signal words; DANGER, WARNING, and CAUTION. The signal words bring attention to the existence and relative seriousness of a hazard.

- **DANGER:** The signal word DANGER indicates an imminently hazardous situation which, if not avoided, will result in death or serious injury
- **WARNING:** The signal word WARNING indicates a potentially hazardous situation which, if not avoided, could result in death or serious injury.
- **CAUTION:** The signal word CAUTION indicates a potentially hazardous situation which, if not avoided, may result in minor or moderate injury.

-Additional Signal Words.

- **NOTE:** The signal word NOTE provides information on operator safety and operator tips.
- **IMPORTANT:** The signal word IMPORTANT indicates a recommended action or a restriction that will ensure correct equipment operation and performance.

Hazards



Preparation for Use



1.) General Guidelines

Every year many unnecessary accidents occur due to improper equipment handling and a disregard for safety precautions. You, the operator, can avoid accidents by observing the precautions in this section.

- The best defense against accidents is a careful and responsible operator.
- The operator should be a responsible adult. Do not allow persons to operate this sprayer until they have displayed a thorough understanding of sprayer safety precautions and operational use!
- Never attempt to operate this sprayer when under the influence of alcohol or drugs.
- ALL replacement parts need to be an OEM part or an aftermarket equivalent
- If there is any portion of this manual that you do not fully understand, please contact the original retailer.
- Review specifications and ensure that this product is only used with a compatible tow vehicle.
- Never exceed the maximum load capacity specified by the manufacturer of the vehicle used to haul this unit.
- Be aware of the owner's manual decal (Figure 2).



Figure 2: Owner's Manual Decal (DE39)

2.) Chemical Warnings

- All operators must also fulfill state pesticide applicator license requirements!
- Be aware of the chemical warning decal on the sprayer tank (Figure 3).
- Read and follow chemical manufacturer's labels, warnings, and instructions! A material safety data sheet (MSDS) should be provided by the chemical manufacturer.
- To avoid injury from chemical hazards, wear the proper protective clothing. Each chemical manufacturer's clothing requirements are listed under the "Personal Protective Equipment (PPE)" section in the chemical instructions.

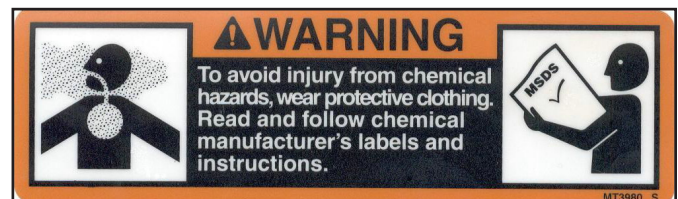

Figure 3: Chemical Warning Decal (DEMT3980)

3.) Pump Precautions

- Never operate the pump at pressures over the manufacturer's recommended maximum pressure. Operating the pump at pressures over the recommended maximum pressure can cause damage to the pump, the controls, or cause personal injury. Operating the pump at pressures over the recommended maximum pressure will void the manufacturer's warranty.
- **IMPORTANT:** Shutting off spray during operation will cause a spike in pump pressure.
- Never pump flammable or explosive fluids such as gasoline, fuel oil, kerosene, etc.
- Never pump liquids at temperatures higher than the recommended maximum temperature (140°F / 60°C) Do not exceed this temperature.
- Before servicing your pump, disconnect the power, release all pressure, and drain all liquids.
- See the pump owner's manual for maximum pressure ratings.
- Do not use the pump to wash or spray: people, animals, delicate items, or live electrical equipment.
- Never pump chemicals whose characteristics are not known.

4.) Spraying Preparation

- Be aware of the location of all the safety and warning decals. Always replace any decals that are illegible or are missing.
- Carefully study and understand this owner's manual.
- Be aware of the owner's manual decal (Figure 4).
- Before adding chemicals, have all operators practice operating the sprayer (clean water only) and its attachments until all operators are completely capable of safe operation.
- Do not wear loose-fitting clothing which may catch in moving parts.
- Visually inspect the sprayer for any worn parts, loose bolts, or other visible problems, and make the necessary repairs.
- All sprayer maintenance should be performed with the sprayer unhooked from the tractor and clean of any harmful chemicals.
- To avoid injury from chemical hazards, always wear the proper personal protective equipment (PPE).
- Make sure the area is clear of any people or obstructions before using the sprayer.

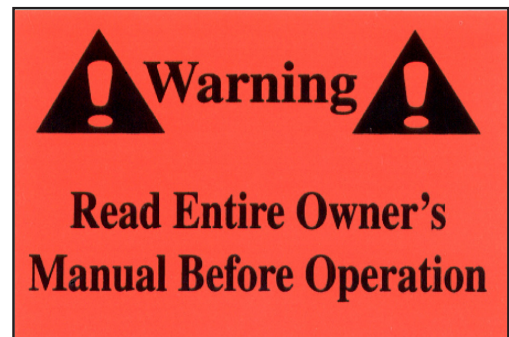

Figure 4: Owner's Manual Decal (DE39)

Safety



During Use



- Always be aware of bystanders, particularly children! Always look before moving the sprayer or the vehicle used to haul it.
 - No passengers are allowed on or in the vehicle or sprayer at anytime.
 - Keep hands and body parts clear of all moving parts.
 - Make sure that the sprayer is properly secured to the bed of the vehicle.
 - Be aware of dangerous terrain such as holes, slopes, drop-offs, banks, rocks, and hidden hazards. Operate the vehicle and sprayer up and down when on steep slopes, not across.
 - Allow for sprayer boom length when making turns.
 - Never leave running equipment unattended!
 - Be aware of dangerous terrain such as holes, slopes, drop-offs, banks, rocks, and hidden hazards.
 - Remember that accidents can even happen to seasoned operators. Always take your time and follow all safety instructions.
-



Clearing Blockages and Cleaning



- Wear chemical resistant gloves and eye protection at all times while clearing blockages and cleaning the sprayer.
 - Before clearing blockages and cleaning, make sure the sprayer and rinse tank is drained entirely.
 - Make sure the sprayer is on level ground before clearing blockages and cleaning the sprayer.
 - Do not stand on the sprayer while clearing blockages and cleaning the sprayer.
 - CAUTION: Be sure to THOROUGHLY wash any skin that has been exposed to chemicals after clearing blockages and cleaning the sprayer.
-



Transporting the Sprayer



- When transporting the sprayer on public roads, always follow state and local regulations regarding safety and transportation requirements. Use the necessary lights and slow moving vehicle (SMV) emblems.
 - Never exceed the vehicle's load and/or tow ratings.
 - Make sure that the sprayer is properly secured to the bed of the vehicle.
 - When transporting the sprayer, the sprayer's boom must be in the fully closed position and secured.
 - Check lighting before traveling.
 - Make sure SMV sign is not blocked or bent.
-

Safety

Maintenance and Adjustment

- Wear chemical resistant gloves and eye protection at all times while performing adjustments and maintenance.
- Make sure sprayer is on level ground before performing adjustments and maintenance.
- Make sure sprayer is clear of all chemical residue in the location where the adjustments are being made.
- CAUTION: Be sure to THOROUGHLY wash any skin that has been exposed to chemicals after performing adjustments and maintenance.

After Use / Storage

- Following operation, stop the vehicle, set the brakes, shut off the engine, and remove the ignition key.
- Completely rinse the entire sprayer and all of its components of all chemical residue after every use.
- Dispose of rinsate in accordance with chemical application guidelines.
- Set the sprayer on a hard level surface, away from all human and livestock activity.
- Do not permit children to play on or around sprayer.

Safety Signs

- Signs and decals used to indicate safe practices while preparing, transporting, and operating the sprayer.
- Make sure that they are not obstructed by dirt or chemical residue. Clean as necessary.
- Replacements can be ordered from a CropCare® Dealer.

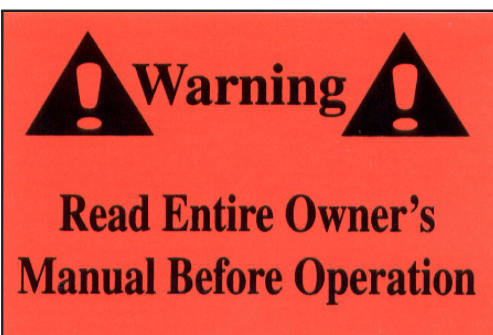

Figure 1: Owner's Manual Decal (DE39)
-Located on the main tank of the sprayer



Figure 2: Chemical Warning Decal (DEMT3980)
-Located on the main tank of the sprayer.

Controls

The controls options on this unit are manually operated, and consist of three adjustments.

1. Pressure Regulating adjustments used to adjust spray pressure.
2. Pressure Release used to set the flow from the pump to bypass entirely to tank or to the pressure setting for spraying.
3. Valves for turning flow to boom sections on or off.

If further help or information is needed please contact your authorized CropCare® dealer for further control assistance.

Control Option 1 (Figure 1)

- Pressure is adjusted by clamping the Pressure Adjustment & Release Lever down.
- With the Pressure Adjustment & Release Lever hooked in the number one position, the pressure is at 100 psi, number two is 250 psi, number three is 450 psi, and number four is 550 psi.
- These pressures can be fine tuned with adjustments of the Pressure Adjustment Knob (NOTE: This can be adjusted when the Release Lever is in the up position).
- Pressure is released (full bypass) when the Release Lever is in the up position.

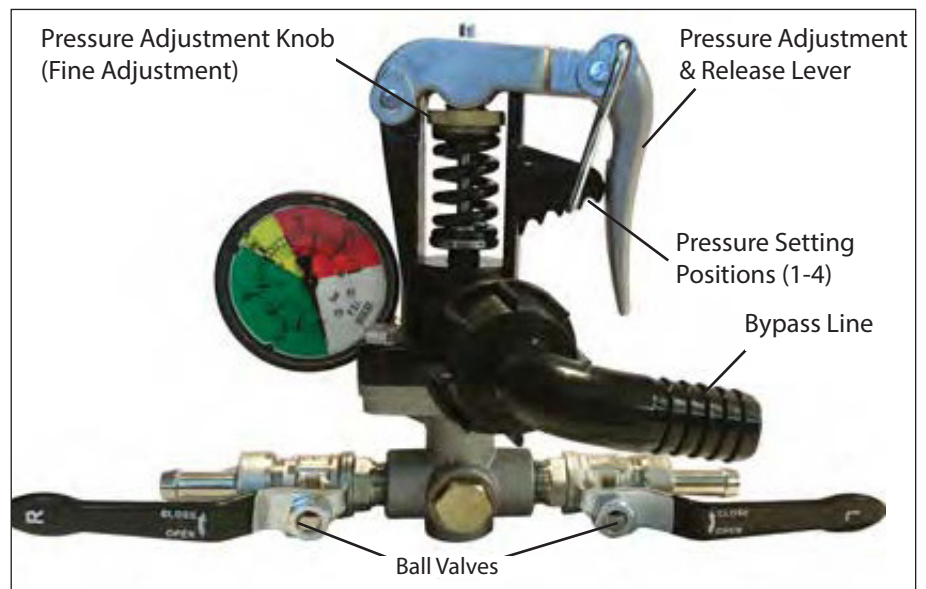

Figure 1: Operator Controls

Control Option 2 (Figure 2)

- Pressure is adjusted by turning the Pressure Adjustment Knob
- Pressure is released (full bypass) when the Pressure Release Knob is set with "C" in the top position.
- When spraying, turn the Pressure Release Knob so that "A" is set in the top position.

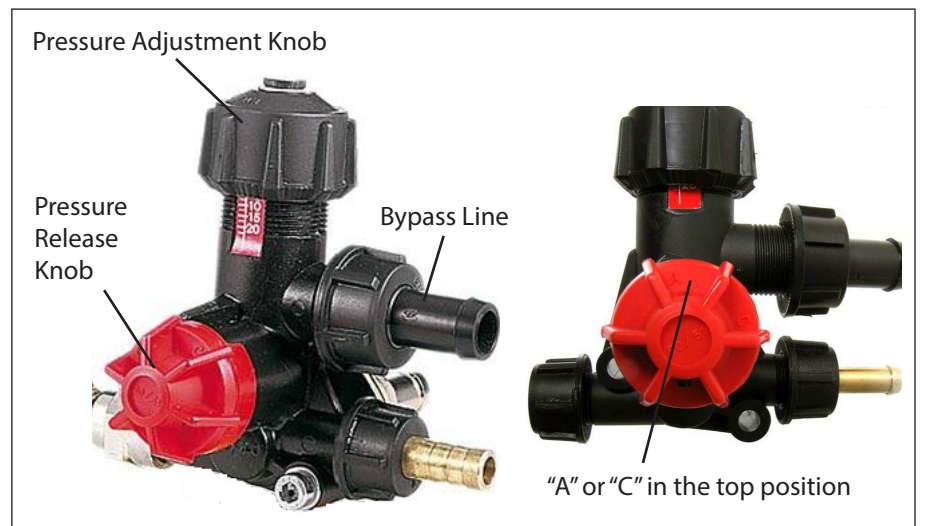

Figure 2: Operator Controls

Operating Instructions

Pre-start Instructions

1.) Preparing the Sprayer

Before operating the sprayer, it is important that you read this entire manual and know all safety precautions. Always take your time and be alert when operating your sprayer. This will allow you to safely spray without accident or interruption.

1. To avoid injury from chemical hazards, wear the proper protective clothing. Each chemical manufacturer's clothing requirements are listed under the "Personal Protective Equipment (PPE)" section in the chemical's instructions.
2. Check the engine oil, fuel, and air filter element. See engine owner's manual for details.
3. Check the pump oil level and accumulator air pressure. See pump owner's manual for details.
4. Fill the sprayer's tank with clean fresh water in order to test the sprayer. Testing the sprayer before operation will give you a chance to familiarize yourself with all of the components and to test for any leaks or problems.
5. Set the controls to have the full flow of the pump bypass to the tank (Figures 1 or 2, Page 9).
6. Set the pressure regulating to the lowest pressure setting before starting the engine and pump (Figures 1 or 2, Page 9).

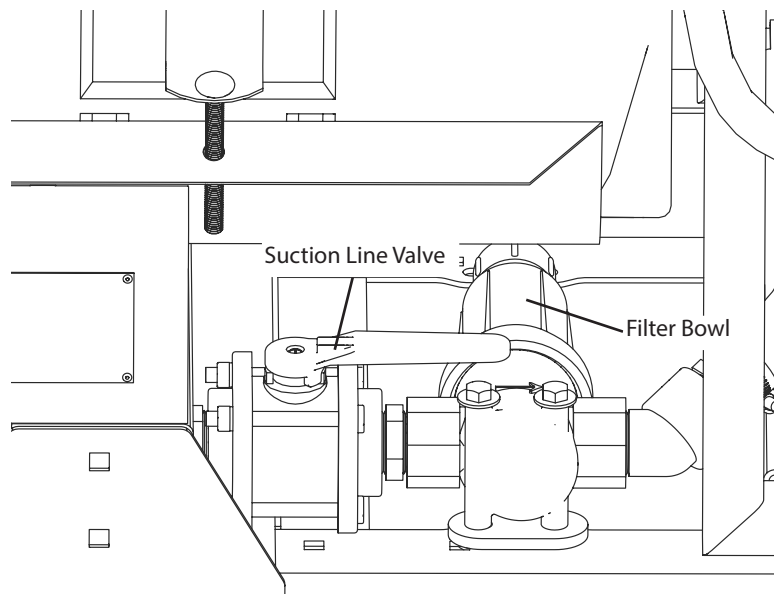

Figure 3: Suction Line Valve

7. Open the suction line valve (Figure 3) located on the side of the frame between the tank and the pump.
8. Start the sprayer's engine and pump (See engine owner's manual for starting instructions). Leave the controls set to the Bypass position until the pump is primed. After the pump has been primed, set the controls to the Pressure position (Figures 1 or 2, Page 9).
9. If a spray boom is installed, calibrate the sprayer using the calibration instructions and calibration chart (See Calibrating the Sprayer). This will determine what pressure to spray at and what nozzles to use in order to achieve the desired GPA.

Operation

2.) Calibrating the sprayer (Only necessary if a boom is installed)

Before spraying, the sprayer must be calibrated to ensure proper spray coverage and the desired application rate. Before calibrating the sprayer it is important to familiarize yourself with the operating instructions. The calibration process is simplified when broken down into the following three steps:

1. Calculate the vehicle speed.
2. Determine the nozzle size and consult the calibration chart for the desired or instructed Gallons per Acre (GPA).
3. Set the pressure accordingly using the pressure regulating adjustment on the spray controls.

IMPORTANT: All calibration must be done with fresh water only!

2a.) Determining the Speed

It is important to determine what speed your vehicle will be traveling at while spraying. While some vehicles may have speedometers, it is still recommended that speed be calculated for all vehicles for accuracy purposes. To determine the speed follow these four steps:

1. Measure a 200 foot or 300 foot distance on a field or a surface similar to where you will be spraying.
2. Drive the equipment and sprayer (half-full is optimal) across the measured distance at a constant rate of speed. There can be no changes in speed while you are measuring the time. This should be a comfortable speed for spraying.
3. Have someone measure the amount of time (in seconds) it takes to travel the measured distance.
4. Your speed can be calculated by entering your data into the equation $\text{Speed (mph)} = (\text{Distance (ft)} \times 60) / (\text{Time (seconds)} \times 88)$ or by consulting the table to the right.

Speed in MPH	Time required (seconds) to travel a distance of:	
	200 feet	300 feet
1.0	136	205
1.5	91	136
2.0	68	102
2.5	55	82
3.0	45	68
3.5	39	58
4.0	34	51
4.5	30	45
5.0	27	41
5.5	25	37
6.0	23	34
6.5	21	31
7.0	19	29

NOTE: It is helpful for future references to record the exact RPM and gear used to find your speed.

2b.) Calculating the GPM and using Calibration Chart

The nozzles on your sprayer are color-coded and match the calibration chart (See the owner's manual included with your boom). Using the tow vehicle speed (determined in step 2a), nozzle size/color, and desired gallons per acre (GPA), reference the calibration chart to find the pressure (psi) necessary to achieve the desired GPA.

IMPORTANT: Due to normal wear, TeeJet® recommends that you replace your sprayer nozzles after every spraying season. Nozzle replacement will ensure accurate spraying performance.

3.) Adjusting the Sprayer Pressure

You have found the correct pressure setting, but must now adjust the sprayer to that pressure setting. (NOTE: See page 9 for control information.)

1. Set the sprayer controls to the full bypass position for the lowest pressure.
2. Then start the engine, and set the sprayer engine's RPM to the RPM to be used while spraying.
3. Adjust the pressure on the sprayer controls to increase the pressure. Continue to adjust until the pressure gauge shows the pressure has reached the desired setting. NOTE: When you open the boom supply line valves or use spray gun to spray, you may need to readjust the pressure.

IMPORTANT: The maximum spray pressure should not exceed the maximum pressure rating of the pump.

4.) Preparing to Spray

NOTE: Proper personal protective equipment (PPE) must be worn at all times while handling, mixing, or spraying chemicals.

1. With the sprayer's engine and pump turned off. Fill the spray tank with the amount of water that is recommended in the chemical mixing instructions.
2. After filling the tank, open the suction line valve (Figure 3, Page 10) located underneath the tank.
3. Set the controls to have the full flow of the pump bypass to the tank.
4. Adjust the sprayer controls to the lowest pressure setting before starting the engine and pump.
5. Start the engine and pump. Leave the sprayer controls set to the full bypass position until the pump is primed.
6. After the pump has been primed, adjust the sprayer controls from full bypass to pressure.
7. Using the pressure adjustment on the controls, adjust the sprayer's maximum spray pressure. **IMPORTANT:** The maximum spray pressure is NOT to exceed the maximum pressure rating of the pump during operation. Doing so may cause damage to the pump.
8. See chemical manufacture's instructions for the proper chemical mixing sequence and the necessary agitation times.
9. Add the amount of chemicals needed for your mixture through the tank fill well.

Operation

Starting Instructions

Beginning to Spray

1. After arriving at spray location, unfold boom wings if needed.
2. Start the sprayer's engine to engage the pump (See engine owner's manual for starting instructions). Ensure that there are no leaks in any of the lines.
3. Using the pressure regulating adjustment on the controls, adjust the sprayer's pressure to the pressure rating found when you calibrated your sprayer. (NOTE: See page 9 for control information.)

IMPORTANT: The maximum spray pressure is NOT to exceed the maximum pressure rating of the pump during operation. Doing so may cause damage to the pump and void the warranty.

4. Open the boom supply line valves, or engage the spray gun by pressing the trigger. NOTE: You may need to readjust the pressure setting on the controls. NOTE: The spray gun tip at the end of the gun can be turned to adjust the spray pattern.
5. During the first few hours of operation, check that the pump's oil level in the tank remains between the minimum and maximum limits. If top-ups are required, use oil of the type shown on the pump data plate.

Shut-Down Instructions

End of Spraying

1. Upon completion of spraying or if the tank is empty:
 - Turn off the boom supply valves.
 - Turn the pressure regulating adjustment to reduce pressure.
 - Set the pressure regulating function of the controls to the by-pass position to discharge pressure.
 - Turn off the engine and the pump (reference the engine owner's manual).

IMPORTANT: Operating the pump when the tank is empty or suction valves are closed will void the manufactures warranty.

2. Upon completion of spraying, always rinse the sprayer with clean water and dispose of all rinsate as directed by the chemical manufacturer.
3. Before storing the sprayer ensure that the sprayer's tank, pump, and plumbing are completely rinsed out. This can be done by manually rinsing the sprayer's tank and running the clean water through the spray nozzles and the spray gun until the system is completely rinsed out. All rinsate must be disposed as recommended by the chemical manufacturer.
4. Excess water can be drained by removing the bowl of the in-line filter (Figure 3, Page 10) located on the side of the sprayer in the suction line.
5. Unload and store the sprayer on a hard level surface in a location away from human and livestock activity.

Instructions for Clearing Blockages and Cleaning

1.) Clearing Blockages

-If the sprayer encounters issues with low spray volume, it may be due to a blockage in one or some of the plumbing components. Some common blockage issues that can occur, along with how to resolve the issue, are detailed in the text below. If any fittings, filters, or plumbing parts are damaged, contact your authorized CropCare® equipment dealer for replacement parts.

NOTE:

-The best way to avoid blockages is to make sure proper agitation is occurring while adding chemicals to tank, applying, and thoroughly rinsing all plumbing components after each time spraying.

-ALWAYS follow the chemical manufacturer's disposal instructions when disposing clean out rinsate and chemical build up.

-Wear all necessary PPE recommended by the chemical manufacturer (i.e. chemical resistant gloves, safety goggles, chemical resistant suit) when clearing out blockages and handling chemical build up.

- Sometimes hose fittings and small diameter hoses can accumulate chemical build up if the sprayer is not properly rinsed after spraying. After locating a clogged fitting or hose, remove it and try to dislodge blockage. Once blockage is removed, reinstall the hose or hose fitting.
- This sprayer is outfitted with a Suction line filter. This filter can become clogged over time from foreign debris or chemical build up. Remove the filter and rinse thoroughly with water until the filter is clean and reinstall it.
- Tanks have sumps and low points that over time can accumulate debris and chemical build up. If debris or chemical build up is spotted in these tanks, use a Shop-Vac to clean out debris in tank. If the chemical build up is hardened in the sump and fittings, disassemble affected fittings and clean out hardened debris or chemical build up. Be sure to clean out Shop-Vac of all chemical build up after clearing blockages.

2.) Cleaning Sprayer

NOTE:

-ALWAYS follow the chemical manufacturer's disposal instructions when cleaning sprayer.

-Wear all necessary PPE recommended by the chemical manufacturer according to chemical manufacturer(i.e. chemical resistant gloves, safety goggles, chemical resistant suit) when cleaning sprayer.

- It is good practice to clean the sprayer, inside and out, after every use. Keeping the sprayer clean helps prolong the life of the sprayer and sprayer components.
- For instructions regarding rinsing the internal components of the sprayer, refer to the "Maintenance Procedures" section.
- Select a soak away area where the cleaning rinsate can be safely be disposed. Most pesticide washings can be washed off on a soak away. A soak away is an area that is currently not being used for crops. That soak away CANNOT directly runoff into wells, springs, streams, water courses, ditches, or sewers.
- A pressure washer can be used to wash down the sprayer. Do not directly spray high pressure water onto electrical components, spray tips, or any other moisture or pressure sensitive components.

Troubleshooting

-Information for fault diagnosis and remedy of problems in operation.

Issue	Probable Cause	Solution
No pressure on start up or Unable to build adequate pressure	Pressure regulating valve set incorrectly (fully opened for bypass, fully closed for spraying)	Use pressure adjustment switch, knob, or handle to increase pressure.
	Flow from tank to pump is inhibited.	Clogged suction hose, fitting, or filter screen, or incorrect valve position (see operation instructions in owner's manual for correct valve position).
	Air leak on suction side of sprayer plumbing	Locate the leak and fix it.
	a. Defective O-ring or gasket in suction filter.	Replace the O-ring or gasket.
	b. Hole or crack in suction hose	Replace hose.
	c. Cracked or broken plastic fitting	Replace fitting.
	Low fluid level in tank	Add material and fluid as necessary to complete application.
	Defective pump seal (evidenced by fluid leak from weep hole)	Replace seal. (See pump owner's manual for details.)
Pressure loss during operation	Defective pump	Repair or replace pump.
	Missing or damaged nozzle	Replace nozzle.
	Clogged suction filter screen	Remove filter screen from filter bowl and clean or replace.
	Low fluid level in tank	Add material and fluid as necessary to complete application.
	Clogged or restricted hose or fitting	Remove hose or fitting and unclog or replace as needed.
	Leak on suction side of sprayer plumbing	Locate the leak and fix it.
	a. Defective O-ring or gasket in suction filter.	Replace the O-ring or gasket.
	b. Hole or crack in suction hose	Replace hose.
Pressure increasing during operation	c. Cracked or broken plastic fitting	Replace fitting.
	Defective pump seal (evidenced by fluid leak from weep hole)	Replace seal. (See pump owner's manual for details.)
Pressure increasing during operation	Inline suction filter screen clogged	Remove filter screen from filter bowl and clean or replace.
Unable to adjust pressure up or down	Pressure regulating on controls set to Bypass all pump flow back to the tank.	Set Pressure regulating to Pressure setting.
Unable to completely reduce pressure with regulating valve	Excessive pump flow	Reduce engine speed.
Pump leaking fluid	Defective pump seal, gasket, or O-ring	Replace seal, gasket, or O-ring. (See pump owner's manual for details.)
	Pump housing damaged	Replace component or pump. (See pump owner's manual for details.)
Pump noisy/pulsating	Flow from tank to pump is inhibited restricted	Ensure that the suction line valve is fully open.
	Clogged suction filter screen	Remove filter screen from filter bowl and clean or replace.
	Insufficient pressure in pulsation dampener / accumulator	Charge dampener with air as specified in pump owner's manual
Pump oil level low, overflowing, or changing color	Pump diaphragms damaged	Replace diaphragms. (See pump owner's manual for details.)

Operation

Troubleshooting

Issue	Probable Cause	Solution
Poor tank agitation	Engine speed is too low	Set engine RPMs higher as needed.
	Clogged or restricted hose or fitting	Remove hose or fitting and unclog or replace as needed.
	Clogged suction filter screen	Remove filter screen from filter bowl and clean or replace.
	Pump not functioning correctly	Repair or replace pump.
Unable to completely empty spray tank	Sprayer tank is not level	Move sprayer to level area, and raise or lower hitch clevis.
Spray nozzles not shutting off (With valves closed)	Section valve not operating or leaking internally	Repair or replace section valve seals/seats.
Spray nozzles not turning on (With valves open)	System pressure too low	Ensure that operating pressure is at least 15 psi.

Maintenance and Adjustments

Maintenance Schedules

Information concerning periodic maintenance tasks and the recommended frequency.

Frequency	Maintenance Tasks
Every Use	Check for broken or stressed parts
	Check for leaks (Tighten hose clamps and replace hoses as necessary)
	Check for loose connections (hardware)
	Flush sprayer fluid system with fresh water
	Suction Line strainer: should be taken out and rinsed.
	Wash the exterior of the sprayer with mild detergent.
Every Season	Spray Nozzles: Check spray pattern imperfections due to wear, replace tips as necessary
	Winterize the sprayer before the temperature falls below 30 degrees F
Refer to Owner's Manuals	Pumps: Refer to your Pump's Owner's Manual for service intervals and details. Failure to follow service intervals will void the warranty. Engine: Refer to the Engine's Owner's Manual for service intervals and details. Failure to follow service intervals will void the warranty.

Maintenance and Adjustments

Maintenance Procedures

Instructions for each task, including identification of any tools, test equipment, replacement parts or other service required.

Every Use

- Perform a visual and physical inspection for any worn parts, loose bolts, damaged hoses, or other visible problems. Make all necessary repairs before spraying. To order parts or receive technical help, please contact your local Zimmerman equipment dealer.
- After each use, ensure that the sprayer's tank, pump, spray nozzles, and spray gun are completely rinsed out. This can be done by rinsing the sprayer's tank and running the clean water through the sprayer's nozzles until the system is completely rinsed out. All rinsate must be sprayed disposed of as recommended by the chemical manufacturer. Excess water can be drained by removing the bowl of the in-line filter.
- The in-line filter screen should also be taken out and rinsed on a regular basis.

Every Season

- At the beginning of the season, using water, check spray patterns on the nozzles. If any spray nozzles appear to be worn, replace as needed.
- The in-line filter should have the screen taken out and rinsed.
- NOTE: Follow chemical manufacturers guidelines for proper cleaning of the strainers.
- NOTE: Be careful not to lose the gasket in the filter bowl (Figure 1). A missing gasket will cause the strainer to leak.
- The winterization process should be undertaken before freezing conditions and/or after each season of use. See the following section for details.

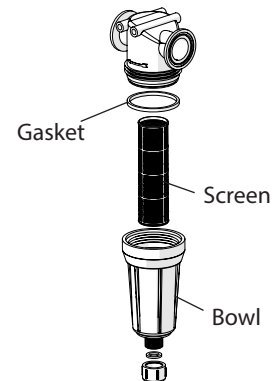

Figure 1: In-line filter

Preparing the Sprayer for Winterizing

It is essential that you winterize your sprayer to avoid damage and to allow for optimal performance. The winterization process should be undertaken before freezing conditions and/or after each season of use. Failure to winterize your sprayer will void the manufacturer's warranty.

1. Verify that the sprayer's plumbing system has been rinsed thoroughly and rinsate has been disposed of according to the chemical manufacturer's recommendations.
2. Drain any remaining water from the sprayer's plumbing system by opening the suction and tank valves. Then remove the drain cap from the suction filter and capture all fluid in a container. When system is drained, ensure that the rubber gasket is in place and replace drain cap onto suction filter. Dispose of liquid according to the chemical manufacturer's recommendations.

Maintenance and Adjustments

Winterizing the Sprayer

1. Pour 1/2 - 1 gallon of nontoxic RV antifreeze (propylene glycol) into the sprayer tank.
2. Note: Do not use standard automotive antifreeze (ethylene glycol). It is toxic to humans and animals and causes a disposal hazard.
3. Engage the sprayer pump and operate tractor at moderate engine speed.
4. Fully open the pressure regulator to allow all of the flow to bypass to the tank for 10 seconds and then close the pressure regulator (NOTE: See page 9 for control details).
5. Open all spray nozzle valves and the spray gun until RV antifreeze is observed spraying from all nozzles or until tank is empty, then disengage pump.
6. Store the sprayer in a dry location, out of the elements and away from human or animal activity.
7. When operating the sprayer for the first time following winterization, flush the sprayer with fresh water to remove the RV antifreeze from the system and thoroughly inspect the sprayer for leaks or any signs of damage as a result of freezing.

IMPORTANT: Do not, under any circumstances, run any petroleum based substance (such as diesel fuel) through the sprayer. This will cause damage to sprayer components and will void the manufacturer's warranty.

Maintenance Materials

-Specifications, including quantities / capabilities for normal maintenance materials, such as:

1. RV nontoxic antifreeze (See "Winterizing The Sprayer" section)
2. Oil for Pump as specified by pump manufacturer (see pump owner's manual).
3. Oil for Engine as specified by engine manufacturer (see engine owner's manual).

Storage

The following procedures are to be taken to prepare the sprayer for storage.

- Before storage, ensure that the sprayer's tank, pump, and spray nozzles are completely rinsed out. This can be done by rinsing the sprayer's tank and running the clean water through the spray nozzles until the system is completely rinsed out. All rinsate must be disposed of as recommended by the chemical manufacturer. Excess water can be drained by removing the bowl of the in-line filter located below the tank.
- Store the sprayer in a safe, dry location away from the elements and human and animal activity.

NOTE: If there will be freezing conditions during storage the sprayer needs to be winterized (See "Winterizing The Sprayer" for details).

Accessories and Attachments

Gas Engine Electric Start Option

Connecting to Battery:

- NOTE: Battery must be a 12-volt battery with an ampere hour rating of at least 18 Ah.
- NOTE: Be careful not to connect the battery in reverse polarity, as this will short circuit the battery.

WARNING: Batteries are hazardous because they contain caustic acid, can emit explosive gases, and can cause electric shock.

WARNING: Caution must be exercised when making connections to a battery to avoid shock and contact with the acid, and to prevent any sparking that could lead to an explosion.

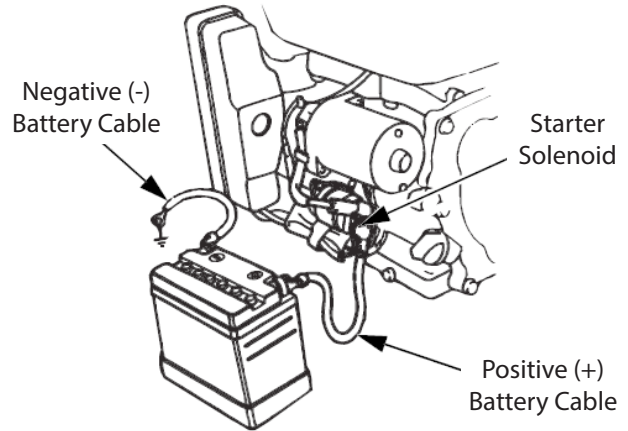

1. Connect the battery positive cable to the starter solenoid terminal as shown.
2. Connect the battery negative cable to an engine mounting bolt, or other good engine ground position.
3. Connect the battery positive cable to the battery positive terminal.
4. Connect the battery negative cable to the battery negative terminal.

NOTE: The engine is not equipped with an alternator to charge the external battery. The external battery will need to be recharged periodically.

Accessories and Attachments

Electric Hose Reel Option

Connecting to Battery:

- NOTE: Be careful not to connect the battery in reverse polarity, as this will short circuit the battery.
 - NOTE: Use a 30 amp fuse in the positive (+) line from the battery to the terminal for inside the junction box.
 - NOTE: Use 10 ga AWC wire for leads from battery.
1. Loosen the four screws to remove the cover from the junction box.
 2. Loosen the strain relief (a) and route wires up through the fitting into the box.
 3. Crimp ring terminals onto the ends of the wires. Attach the positive (+) wire to the terminal (b), and the negative (-) to the terminal (c).
 4. Secure wires in place by re-tightening the strain relief.
 5. Route wires to battery and secure on battery terminals.

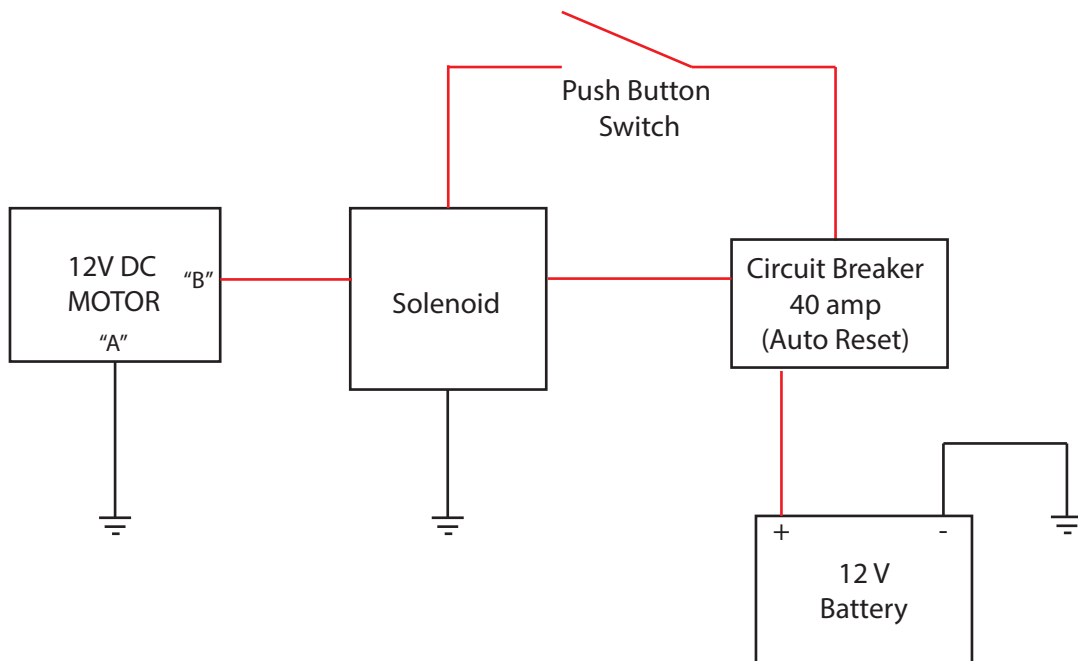
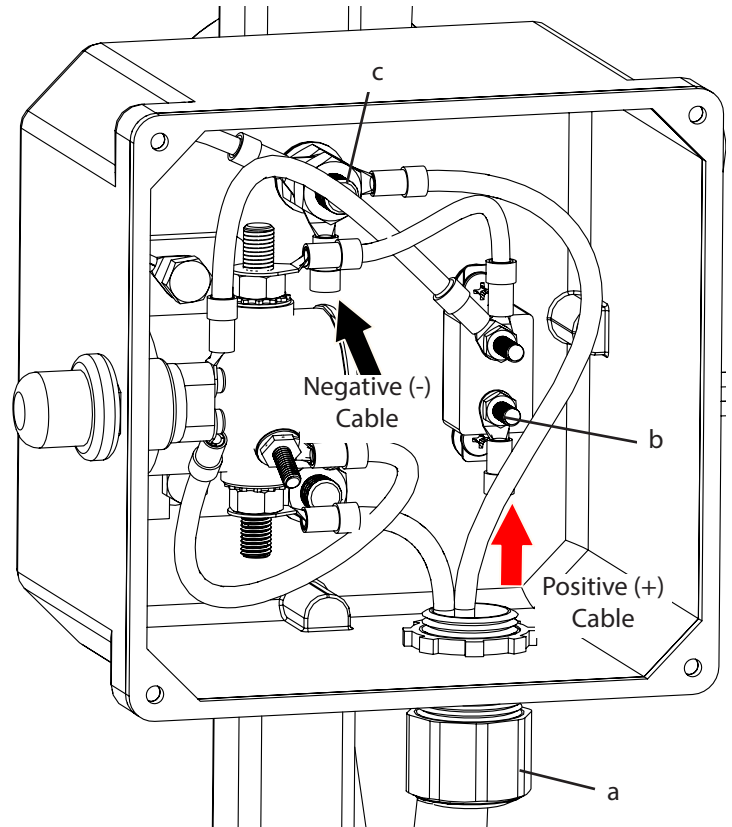

CropCare[®] Limited Warranty

SGX110, SGX150, SGX200, and SGX300.

Warranty Coverage

CropCare[®] hereby provides a Limited Two (2) Year Warranty on SGX Sprayers, manufactured by CropCare[®]. SGX Sprayers manufactured by CropCare[®] are warranted against any manufacturer's defects in any of the sprayer's components in the 24 months following the original date of purchase.

Defective components will be repaired or replaced at the discretion of the manufacturer. It is the responsibility of the purchaser to return warranted components to the manufacturer. This warranty is limited to the repair or replacement of sprayer components only. CropCare[®] is not to be held liable for incidental or consequential damages of any kind. This warranty covers the purchaser of this sprayer and any other owners who own it during the two year warranty period.

To retain the warranty, the sprayer must be operated and maintained as ascribed by its owner's manual. For warranty service, please have a copy of the purchase invoice available.

Warranty Is Void if:

1. The sprayer has been subjected to, in the opinion of CropCare[®], negligent handling, misuse, an accident or if the instructions in the owner's manual were not completely followed.
2. The sprayer's components have been altered in any manner or repairs have taken place with unapproved parts.
3. The sprayer and its components were subject to freezing or freezing conditions. The sprayer must have been winterized as per the maintenance instructions to retain the warranty.
4. A non-compatible chemical was used and/or if the sprayer operator failed to rinse all chemical residue out of the sprayer's components after use.
5. A petroleum-based, oil-based, or flammable product was used and caused damage to the pump, tank, hoses, or any other component.

Getting Warranty Service

All SGX Sprayer warranty claims must be made through the original retailer. All warranty claims must be submitted with an invoice or a proof of purchase that denotes the purchase date and place of purchase. If you have any questions or comments concerning this warranty, please contact the original retailer.

Ordering Parts

Please contact the original retailer to order replacement parts for your product.

CROPCARE

Manufactured by PBZ LLC
A Paul B Zimmerman Inc. Company
www.CropCareEquipment.com